

External view

MCS-3a

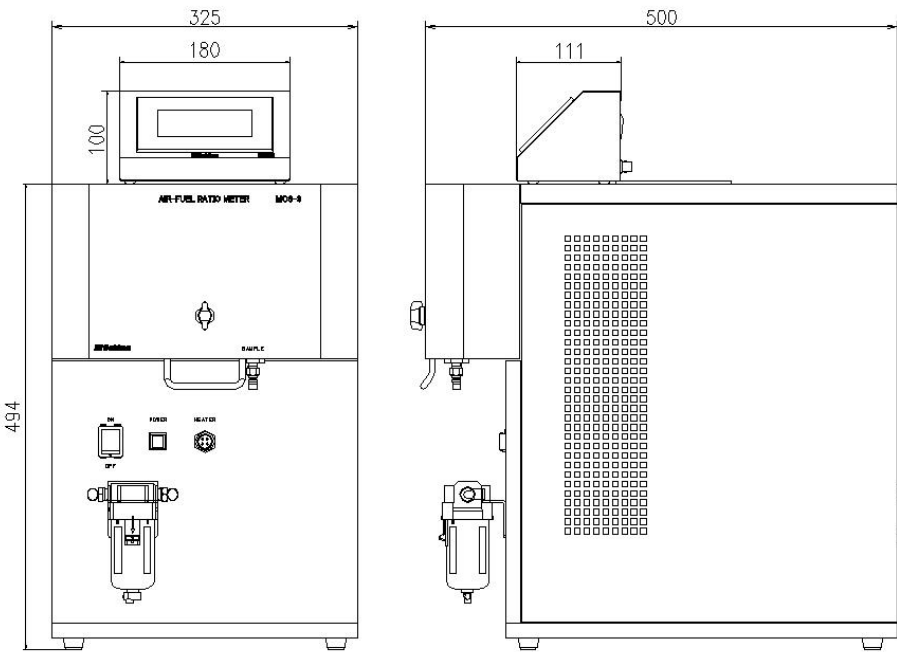

PLR-7

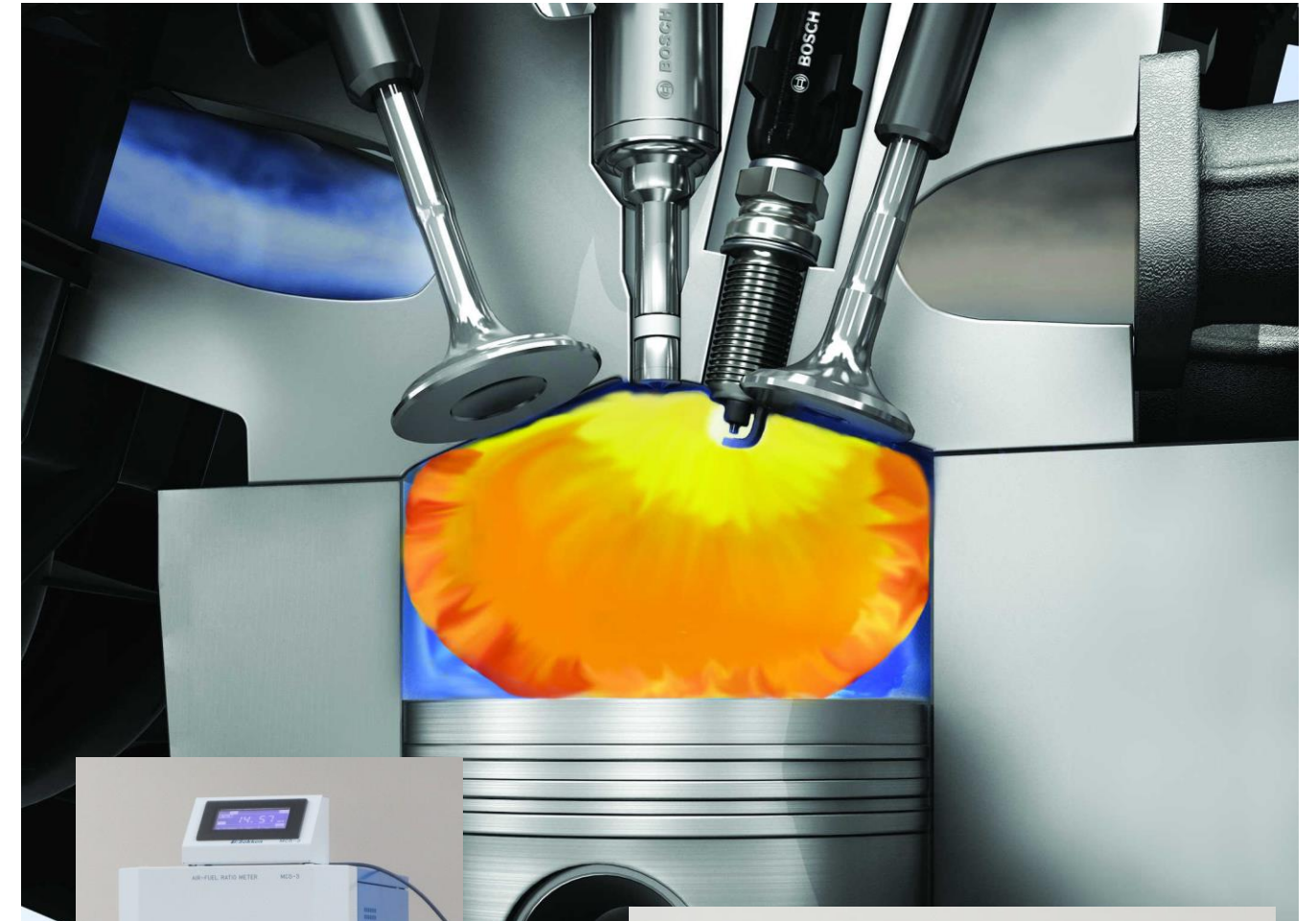
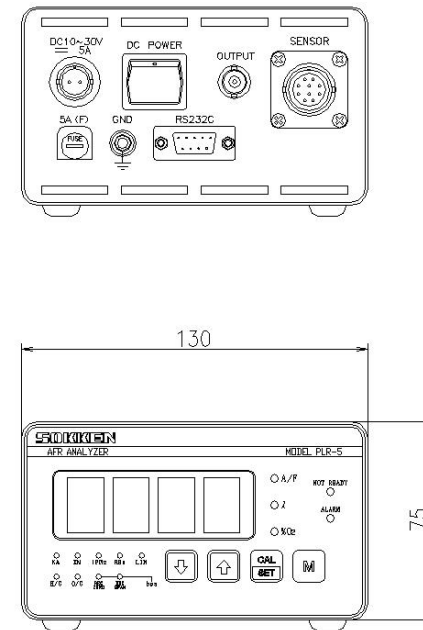

Relevant products

Fast Gas Analyzers for HCs, CO₂ and NO_x

Only Fast Engine Exhaust Gas Analyzers in the world to investigate every engine firing cycles in milli-seconds order.

Useful tools to reduce exhaust emissions and to save fuel economy in transient engine conditions.

Line-up

- Fast HC analyzer HFR500
- Fast CO₂ analyzer NDIR500
- Fast NO_x analyzer CLD500

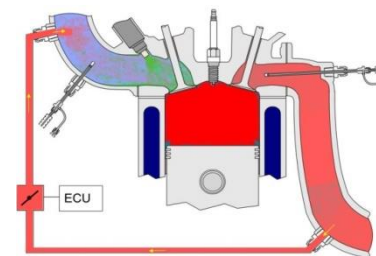
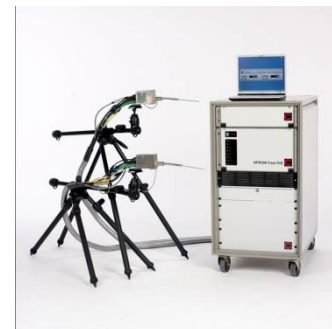

はかるをカタチに

Tsukasa Sokken Co., Ltd.

158-0087 1-19-4 Tamazutsumi
Setagaya-ku Tokyo, Japan
Tel +81 3 3703 4391

www.sokken.co.jp

Mar.2020/AfVer02-En

**Air Fuel Ratio measurement
for Engine Research**

- Calculate AFR from residual Oxygen concentration in exhaust gas
- Fast response for transient engine conditions
- Two types of line-up for High precision and Portable

High precision Air Fuel Ratio Meter

Model MCS-3a

MCS-3a is capable to measure high precision AFR without to be influenced by the coexistence unburned gases such as HCs and CO in rich combustion exhaust gas. The MCS system mainly consists of metering capillaries for sample gas and air, catalyst and a Zirconia Oxygen sensor. The Oxygen concentration is measured by Zirconia sensor after the unburnt gases were fully oxidized over catalyst. The AFR is calculated by the Oxygen concentration and the dilution rate.

Features

- Not affected by the exhaust pressure fluctuation
- Provide the accurate results under cold start or misfire conditions
- Wide dynamic-range (7 – 100 AFR)
- Fast response ($T_{10-90} < 300\text{ms}$)



Applications

MCS-3a

- Optimization of AFR control
- R&D for lean combustion engines

PLR-7

- Applicable for real-world On-board driving use
- Research AFR variation among cylinder to cylinder



Portable type Air Fuel Ratio Meter

Model PLR-7

PLR-7 is the small and light weight air fuel ratio meter by using multiple layered UEGO sensors. It is simple to use by installing the UEGO sensor to exhaust manifold/pipe.

Features

- Easy to use and fully portable
- Wide dynamic-range (9.5 – 60 AFR)
- Fast response ($T_{10-90} < 250\text{ms}$)
- Suitable for On-board use (support 12vDC)
- Analog output 5V / 10V selectable
- Available RS-232C , USB , LAN



Specifications

	MCS-3a	PLR-7	
Dynamic Range	7 - 100AFR	9.5 - 60AFR	
Accuracy	+/- 0.1 7 - 30 AFR +/- 0.3 30 - 50 AFR +/- 1.0 50 - 100AFR	+/- 0.3 9.5 - 14.7 AFR +/- 0.1 14.7 AFR +/- 0.3 14.7 - 20AFR +/- 0.7 20 - 30AFR	+/- 1.0 30 - 40AFR +/- 1.5 40 - 50AFR +/- 2.0 50 - 60AFR
Results displayed	AFR, Lambda, O ₂ , CO	AFR, Lambda, O ₂	
Response time	$T_{10-90} < 300\text{ms}$	$T_{10-90} < 250\text{ms}$ (depend on the sensor position)	
Sensor	Stabilized Zirconia Oxygen sensor	Oxygen pumping UEGO sensor	
Sampling	5L/min with 3m heated sample line	Direct insertion sensor into exhaust manifold	
Sample point pressure	-10 to 200kPa in peak to peak 0 to 50kPa in average	Near atmospheric	
Max. gas temperature	Less than 600C at the probe inlet	-7 - 900°C(recommended 200 – 800C)	
Applicable fuels	Gasoline, Ethanol, Diesel fuel, Propane and the other HCs content fuels		
Warm-up time	Less than 30 minutes	Less than 10 minutes	
Power requirement	100VAC 50/60Hz, Max. 10A	85 - 120VAC, 50VA 10 - 15VDC (with reverse connection protection))	
Analogue output	0 - 10VDC, 50 ohms (Selectable O ₂ , Lambda, AFR)	0 - 5VDC, 50 ohms	
Weight	Main unit <25kg, Control unit < 1kg	Approx. 1kg	
Interface	Ethernet	RS-232C , USB , LAN	